

BM180 PLUS^{MkIII} – ADJUSTABLE WIDTH (100-150 cm / 3.3'- 5') WORKING BENCH

MADE IN ITALY

PATENTED

YouTube
channel:
raimondispa



NEW



min: 100 cm
max: 150 cm

394MAMK3PLUS

"BM180 PLUS^{MkIII}" with folding legs/transport position



PACKAGE



2 "BM180 PLUS^{MkIII}" combined



Working dim.: 360x100 cm

2 "BM180 PLUS^{MkIII}" combined



Working dim.: 360x150 cm

- BM 180 PLUS^{MkIII} is a variable width table designed to be the perfect workstation for large format tiles up to 160 cm (5.3') and to be easy to transport;
- With few simple movements, the width of the worktop can vary from a minimum of 100 cm (3.3') to a maximum of 150 cm (5') with intermediate steps;
- In order to obtain an optimal worktop for any chosen width, the aluminum profiles are easily movable;
- When changing the width of the table the legs move as well, therefore they always maintain the optimal position to guarantee the maximum stability and strength of the bench at any chosen width;
- Stable and robust thanks to the steel structure, the proportions and dimensions of the legs and crossbars as well as the effective leg clamping system;
- The length of the top is 180 cm (5.9'), extendable up to 283 cm (9.3') with an extension (accessory). Connect two tables together to obtain a worktop of 360 cm (11.8') in length (and variable with from 100 to 150 cm – 3.3' to 5'). This feature makes the BM180 PLUS the perfect workstation for slabs of any size;
- The leg closing system allows a very quick and easy closing of the legs;

- Being the anodized aluminum profiles (which make up the worktop) spaced and movable, it is possible to perform cuts with angle grinder and diamond blade without damaging them. Moreover, the special tile-support-cylinders (available as an accessory) create a gap between the tile and the worktop allowing to perform cuts with angle grinders in every direction without damaging the bench;
- It possible to eventually add extra aluminum profiles (accessory);
- Height of the workbench from the ground adjustable from 80 to 86 cm thanks to the adjustable feet;
- Double ring-nut feet: by rotating the lower ring-nut you adjust the height (no tool needed), by tightening the upper ring-nut you lock the foot in the desired position;
- Maximum load capacity (single table): 150 Kg (331 lbs);
- Wide range of accessories available.

SPECIFICATIONS AND VERSIONS

Part No.	Barcode	Description	Weight	Dimensions	Volume
394MAMK3PLUS	8050532024762	1 BM180 PLUS ^{MkIII} - Adjustable width (100-150 cm / 3.3'- 5') working bench with folding legs	32,8 Kg / 72.3 lbs	117x20x h 20 cm + 190x21x h 10 cm	46"x8"x h 8" + 75"x8"x h 14"

ACHIEVABLE WORKTOP DIMENSIONS WITH TWO BM180 PLUS^{MkIII} BENCHES ONLY

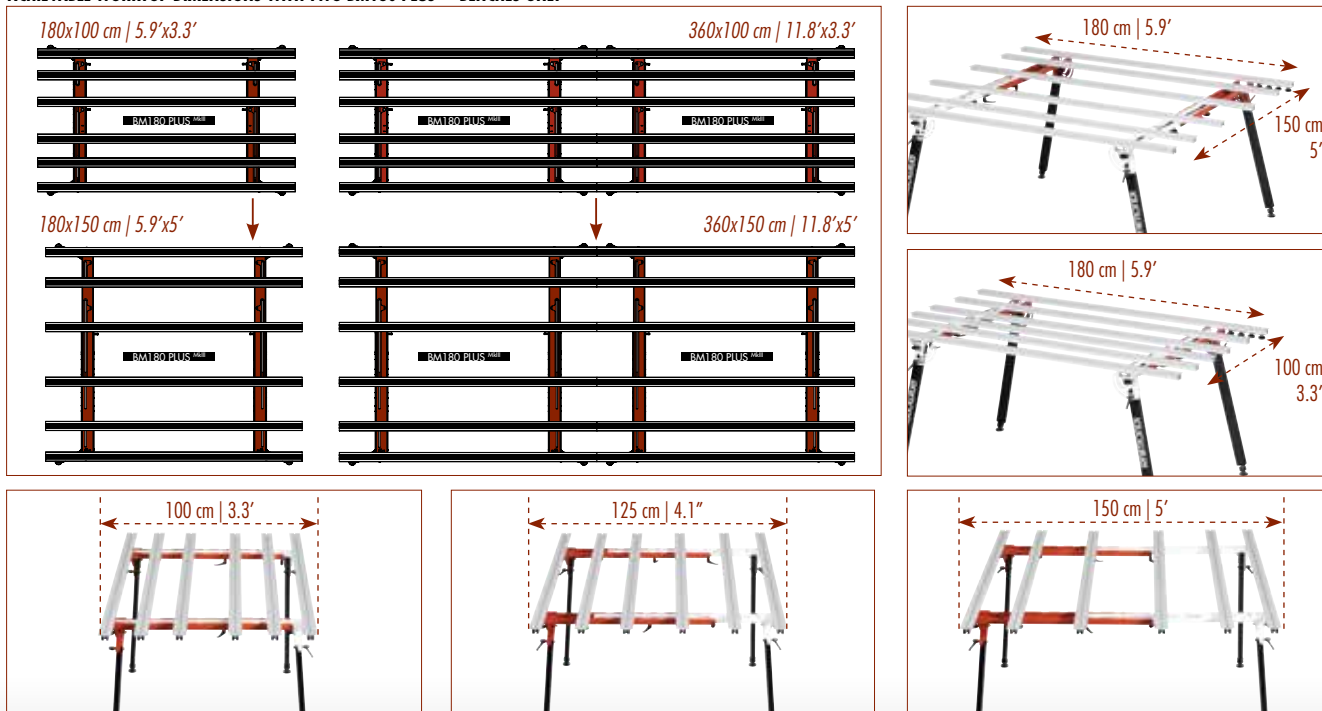

TOOLS FOR LARGE FORMAT TILES

EXTENSIONS FOR BM180 WORKING BENCHES

MADE IN ITALY



394CP270A



min: 100 cm
max: 150 cm

394CP270APLUS



394EST 01A

"BM180 PLUS" with extension 394CP270APLUS.



PACKAGE



CARTON BOX

SPECIFICATIONS AND VERSIONS

Part No.	Barcode	Description	BM180 <small>MkIII</small>	BM180 PLUS <small>MkIII</small>	Weight	Dimensions	Worktop Dimensions	Weight
394CP270A	8050532005136	Side extension complete w/6 aluminum profiles and folding legs to lengthen the bench of 103 cm (3.4') - tot. 283 cm (9.3')	•	–	11,6 Kg / 25.6 lbs	117x20x h20 cm	46" x 8" x h 8"	12,5 Kg / 27.5 lbs
394CP270APLUS	8050532000599	Telescopic extension (100-150 cm/3.3'-4.9') to lengthen the bench of 103 cm (3.4') - tot. 283 cm (9.3')	–	•	6,2 Kg / 13.7 lbs	140x14xh 8 cm	55 1/8" x 5 1/2" xh 3"	7,2 Kg / 15.9 lbs
394EST 01A	8050532000124	Telescopic extension to widen the bench up to 60cm - 23 5/8" (tot. width 150 cm - 4.9')	•	–	8,2 Kg / 18.1 lbs	190x Ø17 cm	46" x Ø 8"	10,2 Kg / 22.5 lbs

ACHIEVABLE WORKTOP DIMENSIONS WITH TWO BM180^{MkIII} AND EXTENSIONS

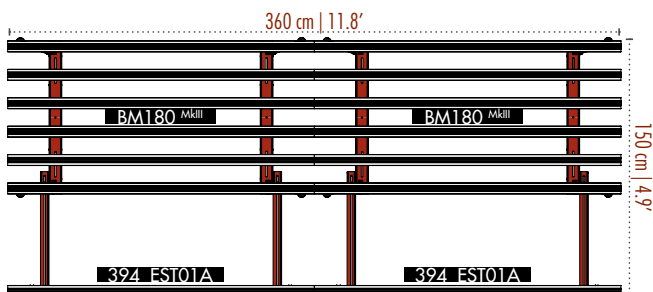
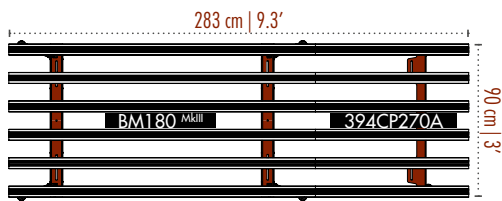
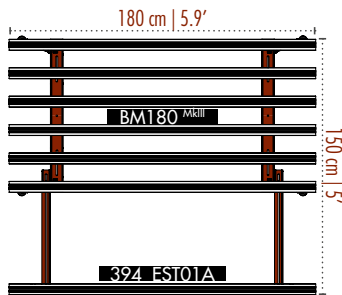

ACHIEVABLE WORKTOP DIMENSIONS WITH ONE BM180 PLUS^{MkIII} AND EXTENSIONS

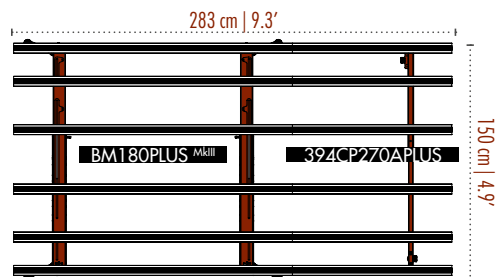
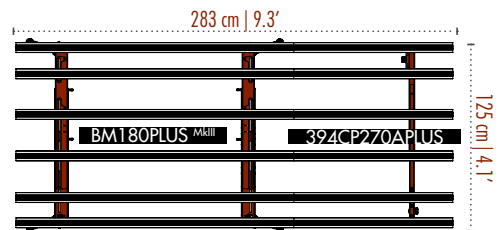
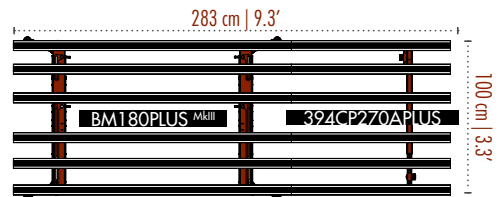

TOOLS FOR LARGE FORMAT TILES



1x BM180 ^{MkIII} + 2x 394EST 01A
Worktop dim.: 360x150 cm



1x BM180 ^{MkIII} + 1x 394CP270A
Worktop dim.: 283x90 cm

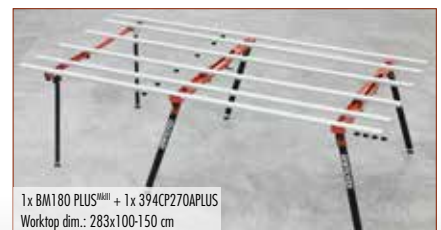

1x BM180 PLUS ^{MkIII} + 1x 394CP270APLUS
Worktop dim.: 283x100-150 cm



"TSE180" with folding legs/transport position.



"TSE180" mounted on 2 "BM180 PLUS" combined.



"TSE180" mounted on 1 "BM180 PLUS".

PACKAGE



- The new lateral tilting extension supports the tile and facilitates splitting after scoring during the cutting process. It also prevents the cut portion from falling.
- The device allows the support of the tile both during and after the splitting phase.
- Splitting can be performed by one single operator.
- Extremely easy to be installed/removed either on a single or on multiple workbenches connected

- together
- Whenever not in use, it can be completely tilted down below the workbench.
- Legs are equipped with adjustable feet for a perfect alignment with the workbench.
- Anodized aluminum profiles with adjustable position to optimize the worktop
- Fully suitable with both BM180 and BM180PLUS workbenches.

SPECIFICATIONS AND VERSIONS

Part No.	Barcode	Image	Description	Weight	Dimensions	Volume
394RB RAI	8050532024038	1	TSE180 – lateral tilting extension for BM180 benches	18,8 Kg 41.44 lbs	186x27xh 18 cm 73"x10 5/8"xh 7"	21,5 Kg 47.39 lbs

POSSIBLE COMBINATION WITH BM180 BENCHES

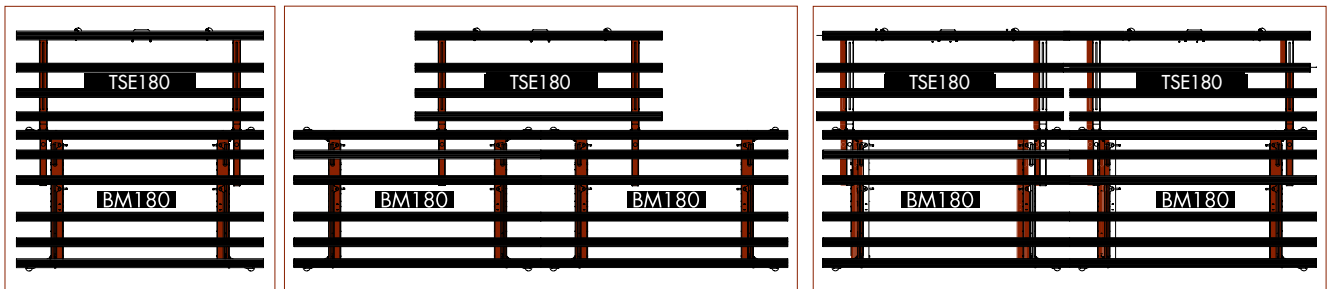

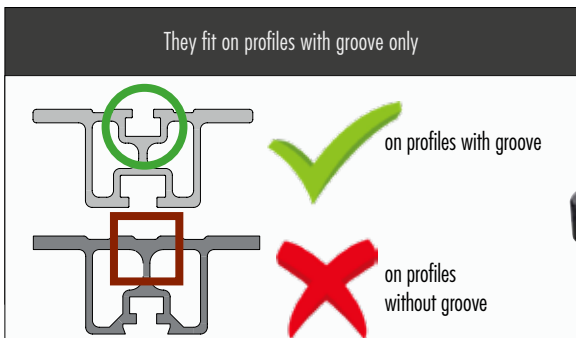

PACKAGE



KIT OF 20 TILE-SUPPORT CYLINDERS TO PERFORM CUT WITH ANGLE GRINDER ON BM180^{MkIII} AND BM180 PLUS^{MkIII} TABLES

- To perform with ease cuts with angle grinder (even l-shaped and/or squares holes) on tiles up to 160x320 cm (5.3'x11.9') in any direction.
- One kit consists of 20 polypropylene supports (h56 mm - Ø 60 mm | h2.2" - Ø 2.4") that once inserted along the aluminum profiles, supports the tile and creates a gap between it and the worktop. This allows to perform cuts with angle grinders in any direction without damaging the bench.
- The possibility to freely positioning the cylinders at any point on the worktop allows to choose their layout according to the tile dimension and the kind of cut to be done. Even in the most difficult situations and for the most complex cuts.
- Inserting and fixing is extremely easy and fast: just insert the screw underneath each cylinder into the dedicated slot of each aluminum profiles (which made up the worktop) and slide the supports in the desired position. Slightly rotate the cylinders to fix them.
- Its design and the premium quality polymer they are built with make the cylinders extremely sturdy. They are designed to support tiles of any weight and to last potentially forever.
- The supports are compatible with both BM180^{MkIII} and BM180 PLUS^{MkIII} as well as previous versions if equipped with top-grooved aluminum profiles.
- The supports do not preclude the use of the wide range of accessories dedicated to BM180 tables nor the use of POWER-RAIZOR both in combination with water-cut kit (Art.433PWWA) and/or the dust suppression device for dry cut (Art.433PWZPA).

SPECIFICATIONS AND VERSIONS KIT TILE-SUPPORT CYLINDERS

Part No.	Barcode	Box	Description	BM180 ^{MkIII}	BM180 PLUS ^{MkIII}	Use	Weight	Dimensions	Volume
394CC 01A	8050532004207	1	Kit of 20 tile-support cylinders for BM180 ^{MkIII} and BM180 PLUS ^{MkIII}	•	•	on profiles with groove	0,9 Kg 1.9 lbs	39x39xh 15 cm 15 3/4"x15 3/4"x h 6"	1,2 Kg 2.8 lbs

SIDE PROFILES FOR SCORING AND CUT

- The side profile connects to the short side of the table offering a continuous support for score & cut the short side of the tile (i.e.: cut 120 cm side of a 120x240 cm tile).
- Available in two lengths: 124 cm and 164 cm (4' and 5.4'). Therefore, suitable even for the largest tiles.
- We recommend the use of the 164 cm (5.4') version only with BM180 PLUS^{MkIII}.
- Version 124 cm (4') fits on both BM180^{MkIII} and BM180 PLUS^{MkIII}.
- Free to slide in and out when mounted so to not interfere with operator when doesn't need them.

SPECIFICATIONS AND VERSIONS FOR SIDE PROFILES FOR SCORING AND CUT

Part No.	Barcode	Box	Description	BM180 ^{MkIII}	BM180 PLUS ^{MkIII}	Weight	Dimensions	Volume
394IS 1200	8050532007024	1	Side profiles for scoring and cut length 124 cm (4')	•	•	-	-	-
394IS 1600	8050532007031	1	Side profiles for scoring and cut length 164 cm (5.4')	-	•	-	-	-



TOOLS FOR LARGE FORMAT TILES

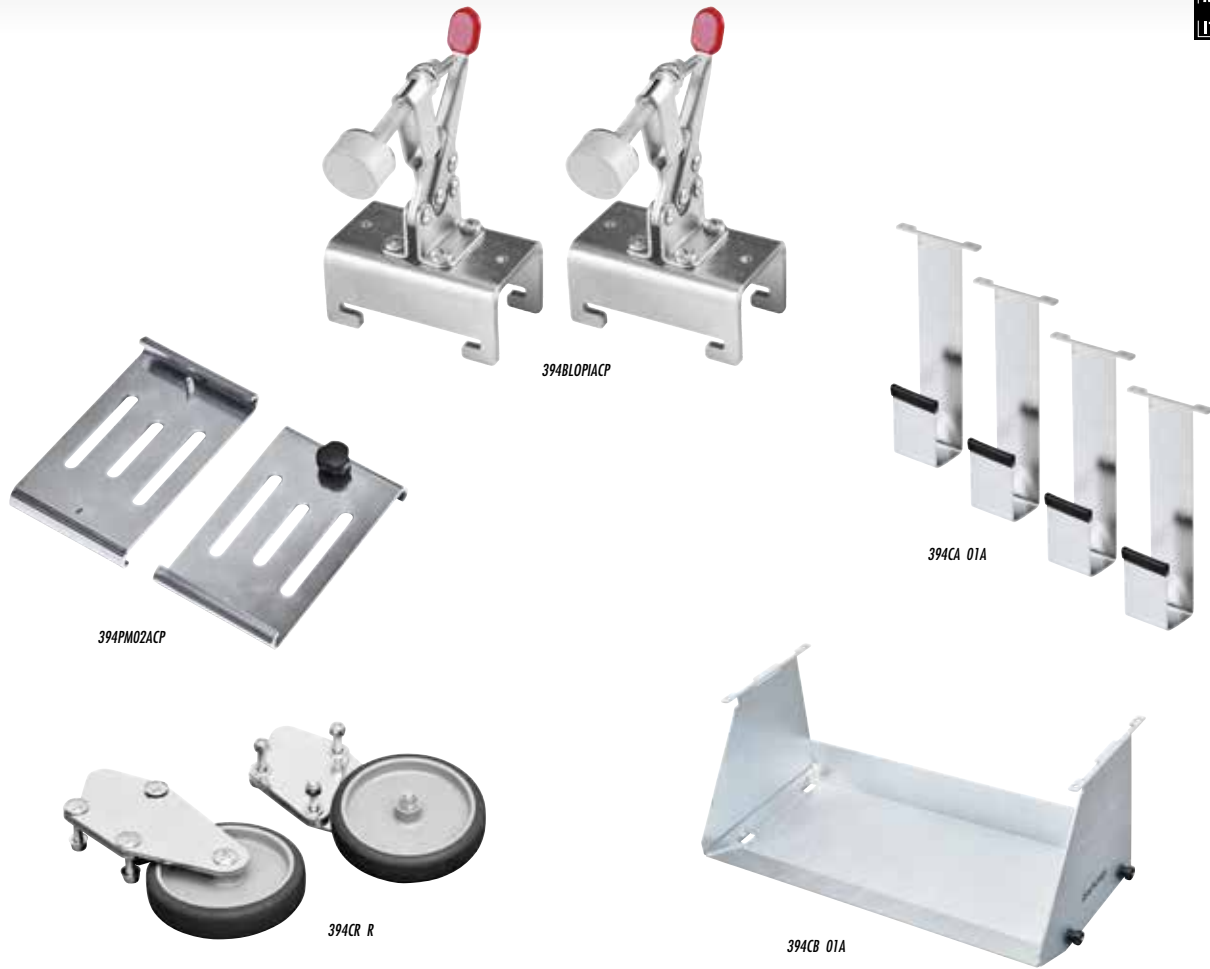

SPECIFICATIONS AND VERSIONS

Part No.			Description	BM180 ^{MkIII}	BM180 PLUS ^{MkIII}			
394BLOIACP	8024648096678	1	Stand-alone tile holder (for 3 to 30 mm thicknesses) - pair	•	•	0,9 Kg 2 lbs	27x15xh 10 cm 10 5/8" x 4" xh 6"	1 Kg 2.2 lbs
394PM02ACP	8024648096722	1	Strips support - pair	•	•	0,6 Kg 1.3 lbs	27x15xh 10 cm 10 5/8" x 4" xh 6"	0,7 Kg 1.5 lbs
394CR R	8050532000940	1	Wheels for legs - pair	•	•	1,7 Kg 3.7 lbs	27x15xh 10 cm 10 5/8" x 4" xh 6"	1,8 Kg 4 lbs
394CA 01A	8050532002364	1	Kit of 4 lateral steel hooks for hang up the cutting guides	•	•	0,5 Kg 1.1 lbs	37x17xh 8 cm 13" x 6 5/8" xh 3"	2 Kg 4.4 lbs
394CB 01A	8050532002388	1	Steel-made side tools box	•	-	4.9 Kg 10.8 lbs	58x28xh 23 cm 23" x 11" xh 9"	5,4 Kg 11.9 lbs



TOOLS FOR LARGE FORMAT TILES